

OSPAR Convention for the Protection of the Marine Environment of the North-East Atlantic

Meeting of the OSPAR Commission (OSPAR)

Bergen: 20-24 September 2010

New Working Structure

Presented by the Secretariat

This document proposes a new working structure for OSPAR as of 2010 / 2011

Background

1. Over the last two years there has been an active discussion about how the working structure of OSPAR should evolve to meet new challenges. A strategic Workshop in Haslemere UK (13-14 May 2008), successive meetings of ICG-Bergen and considerations by main Committees during 2009-2010 have contributed to this proposal.
2. Key drivers for change have included a changing balance of work (more emphasis on biodiversity, less on pollution sources), OSPAR's forthcoming role to facilitate implementation of the Marine Strategy Framework Directive (MSFD), and a requirement for greater efficiency and flexibility.

Structure Proposal

3. The new working structure proposed remains consistent with the OSPAR Rules of Procedure and has been endorsed by HOD. It is constituted to facilitate and deliver the Ecosystem Approach as set out in Part 1 of the North-East Atlantic Environment Strategy 2010-2020 (the Strategy).
4. The structure, which is set out in the organisational diagram and associated table as at Annex 1, comprises:
 - a. The OSPAR Commission;
 - b. 5 main Committees (Hazardous Substances and Eutrophication, Offshore Industry, Radioactive Substances, Biodiversity and Environmental Impact of Human Activities);
 - c. A Coordination Group (a policy-driven working group reporting directly to the OSPAR Commission);
 - d. The Meeting of Heads of Delegation to the Commission and the Committee of Chairmen and Vice-Chairmen;
 - e. The Group of Jurists and Linguists; and
 - f. Expert Groups (comprising working groups and intersessional correspondence groups, as established by main Committees and approved by the OSPAR Commission annually).
5. In addition the Rules of Procedure make provision for a main Committee, as an exception, to establish an *ad hoc* working group if this is necessary to fulfil its work programme in due time.
6. The new Coordination Group (CoG) is proposed in response to recognition that OSPAR work needs to be integrated in order to deliver the Ecosystem Approach., including oversight of information flow between

main Committees, weighting of priorities and resource implications. Terms of Reference for CoG are presented in Annex 2.

7. Terms of Reference for the main Committees have been simplified and drafted to be consistent with the Strategy. Respective responsibility for MSFD Good Environmental Status (GES) descriptors is explicitly articulated. These are presented in Annex 3.

Action requested

8. OSPAR is invited to approve:
 - a. the proposed new working structure;
 - b. the draft Terms of Reference for the new Coordination Group; and
 - c. the draft Terms of Reference for the proposed main Committees, subject to the resolution of a number of outstanding drafting suggestions.

OSPAR Structure 2010/2011

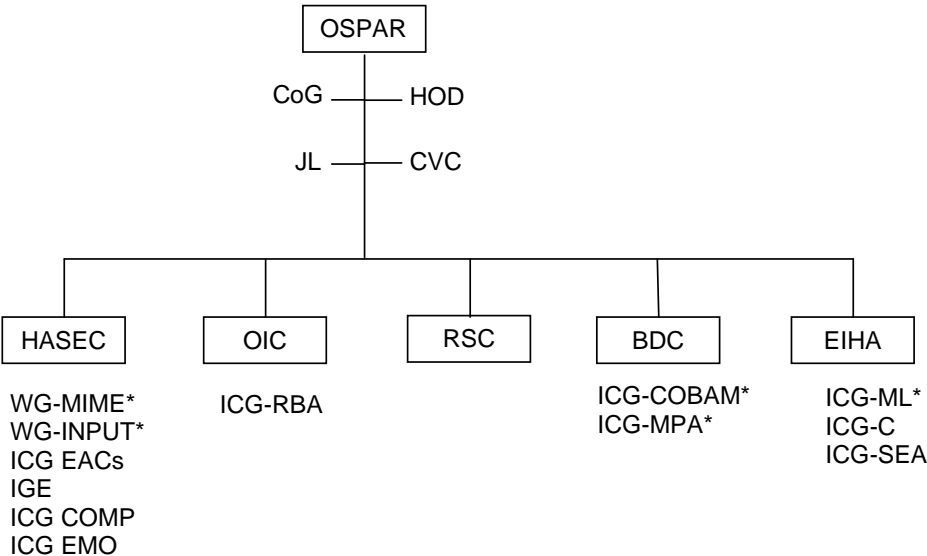

*Meetings planned/proposed

Expert Groups 2010/2011

Parent Committee	Topic	WP Ref	Criteria to justify possible Secretariat support in 2010/2011
OSPAR	Coordination of implementation of ecosystem approach, MSFD and JAMP Theme A (WG-CoG)		Long-term requirement to deliver Strategy
HASEC	Monitoring and assessment tools (WG-MIME, ICG-EACs)	ASMO 11,12,13,18	Long-term annual products. Consideration of guidelines, joint tools and annual assessment of CEMP data
	Atmospheric and riverine inputs/direct discharges (WG-INPUT) ¹	ASMO 19, 20, 21,22	Long-term annual products. Collective review of external reports, review of principles and component coverage
	Review of monitoring strategies for OSPAR chemical for priority action	ASMO 23	Coordination of expertise from different groups (Task manager yet to be agreed)
	Review of the Common Procedure (ICG-COMP)	EUC 1	Key task, conflicting views, policy relevance, (MSFD, WFD, HELCOM)
	Confidence tests of models (+ other target and objective setting issues) (ICG-EMO)	EUC 7, 8 [9]	Long-term, regular workshops as required, not annual
	Substance de-selection (IGE)	HSC 1	Negotiation of expert advice, if any proposals from industry comes along
OIC	Risk-based approach to produced water (ICG-RBA)	OIC 6	
RSC	Concentration data management	RSC 2	Workshop proposal joint with HELCOM
BDC	Biodiversity monitoring and assessment (ICG-COBAM)	BDC 3,4,5,7,8	MSFD relevance
	OSPAR MPA network (ICG-MPA)	BDC 15,16,17 [18,19,20]	Annual report Coherence issues Collaboration with other competent authorities
EIHA	Marine litter (ICG-ML)	BDC 35,36,38, 39	MSFD relevance
	Cumulative impacts (ICG-C)	BDC 42	Future overview assessments
	Economic and social analysis (ICG-SEA)	BDC 43	Regional socio-economic analysis for the OSPAR Maritime Area
	North Sea Network of Investigators and Prosecutors (WG-NSN)		Standing informal group Providing OSPAR and BONN bridging link

¹ INPUT is currently a Working Group and there is a case for it to continue as such, although participation and chairmanship need to be clarified. Alternatively if INPUT becomes an ICG, consolidated reports could be delivered direct to HASEC without the need for an intersessional meeting.

Coordination Group (CoG) Terms of Reference

Terms of Reference for the Coordination Group (CoG): as revised by HOD(3) 2010²

1. The function of the Coordination Group (CoG) is to ensure integration of OSPAR work and delivery of the Ecosystem Approach in line with the OSPAR Strategy. CoG is a high-level subsidiary body of OSPAR comprising representatives of all Contracting Parties supported by their technical experts as appropriate, Observers, and the Chairmen of all main Committees. CoG should meet annually unless otherwise specified by the OSPAR Commission.

Key activities

2. In accordance with the OSPAR Strategy, CoG shall integrate and give guidance to the work of OSPAR through:

- a. Delivery of the ecosystem approach, making sure that all elements for its implementation are taken into account, including integrated management of human activities, weighting of priorities and resource implications;
- b. Coordinating the facilitation by OSPAR of Contracting Parties in their implementation of the Marine Strategy Framework Directive (MSFD) within the OSPAR Maritime Area;
- c. Oversight of Theme A of the Joint Assessment and Monitoring Programme (JAMP) including any holistic assessments needed in future to assess the status of the North-East Atlantic;
- d. Key cross-cutting issues (projects) as identified by OSPAR; and
- e. Whether there is sufficient flow of information between main Committees.

3. In doing so CoG should pay particular attention to the conclusions and recommendations of the QSR 2010, the OSPAR MSFD Roadmap, the JAMP 2010-2014 and cooperation with other European Regional Seas Conventions where appropriate.

MSFD³

4. CoG shall coordinate the facilitation by OSPAR of Contracting Parties in their implementation of the MSFD by Contracting Parties to OSPAR in accordance with the Road Map developed by OSPAR. To this end the CoG shall:

General

- a. Initiate closer coordination at the sub regional level and consider establishing regional task teams if appropriate
- b. Facilitate making best use of the benefits of working jointly with other European Regional Seas Conventions to allow comparisons across borders of respective maritime areas.

With regard to Initial Assessments

² HOD(3) 2010 agreed that based on advice from CoG these Terms of Reference should be evaluated after 2 years (i.e. at OSPAR 2012).

³ Iceland, Norway and Switzerland are not Members of the European Union. As members of the European Economic Area (EEA), Iceland and Norway are bound by certain EU legislation, while Switzerland has not committed itself to apply any EU legislation in the scope of the OSPAR Convention. These three countries contribute on the basis of relevant OSPAR measures, equivalent national legislation and EU legislation by which they are bound (if relevant).

- c. Identify whether any collective OSPAR actions are necessary to address data gaps identified in the QSR 2010 to be taken forward by the main Committees
- d. Identify work on socio-economic aspects to be taken forward by the main Committees

With regard to determination of Good Environmental Status and development of associated targets and indicators

- e. Consider how far OSPAR could assist in the development of regional targets and indicators for the MSFD taking into account developments of criteria and methodological standards in the European Union
- f. Coordinate the work of the main Committees in facilitating the development of targets by Contracting Parties (as an expanded set of EcoQOs or their equivalent)

With regard to monitoring and assessment

- g. Consider where collective OSPAR action on monitoring activities (linked to GES) could most coherently and cost effectively be carried out
- h. Take account of new and emerging issues in the period 2010 – 2020 and develop a further revision of the JAMP to meet the regional monitoring requirements of MSFD by 2014

With regard to programmes and measures

- i. Consider whether the measures required to achieve the objectives of the MSFD are coherent and coordinated across the OSPAR Convention Area.

JAMP

5. Working closely with the main Committees and taking into account their annual reports, CoG shall have oversight of the periodic review of the condition of the Maritime Area, and the overall effectiveness of the measures taken and planned, providing advice on priorities for action in accordance with Article 6 and Annex IV of the OSPAR Convention. To this end CoG shall implement Theme A of the JAMP.

Key cross-cutting issues and integration of OSPAR work

- 6. CoG shall take oversight of cross-cutting issues, specifically but not limited to:
 - a. Marine spatial planning
 - b. Socio-economics
 - c. Cumulative effects
 - d. Climate change related issues
- 7. CoG shall also consider progress reports from each Committee

Operation

- 8. The Chairman of the Commission or his/her nominee shall Chair CoG.
- 9. CoG shall report annually on its work to the OSPAR Commission and advise the OSPAR Commission on specific questions related to its work remitted to it by the OSPAR Commission.
- 10. If needed CoG may establish ICGs as required to progress individual products set out in its annual Programme of Work.

Terms of Reference for the Biodiversity Committee (BDC)

1. The function of the Biodiversity Committee (BDC) is to facilitate the implementation of the OSPAR Strategy and in particular relevant parts of the thematic Biodiversity Strategy.

Strategy implementation

2. In accordance with the Biodiversity Strategy, BDC shall:

- a. ensure the protection and conservation of threatened and declining species and habitats
- b. encourage restoration, where applicable, of marine areas that have become degraded
- c. further develop the OSPAR network of marine protected areas; and
- d. promote regional coordinated biodiversity monitoring and assessment.
- e. [assess and monitor emerging issues, e.g. acidification].⁴
- f. [address relevant MSFD implementation, monitoring and coordination requirements]⁵

3. In doing so BDC shall pay particular attention to the conclusions and recommendations of the QSR 2010 on species, habitats and ecosystem functioning, and further develop programmes and measures needed to halt loss of biodiversity.

4. BDC shall also maintain appropriate interaction with other international organisations.

MSFD GES descriptors

5. BDC shall in particular take account of the need by Parties to develop indicators, targets and monitoring programmes associated with Descriptors 1,[2⁶], 3, 4 and 6, and the need to assess progress towards the achievement of good environmental status. In doing so BDC shall seek to:

- a. improve the status of species and habitats on the OSPAR List
- b. strengthen ecosystem connectivity and resilience
- c. protect and conserve known generic diversity; and
- d. undertake monitoring to inform the control of pathways for major invasive alien species in marine and coastal ecosystems.

Monitoring and assessment

6. BDC shall maintain appropriate monitoring and assessment in line with the JAMP 2010-2014, paying particular attention to:

- a. further developing EcoQOs or their equivalent, including appropriate methodologies to deliver the MSFD
- b. species and habitat action plans
- c. coordinated research on biodiversity issues
- d. raising awareness of threats to species and habitats, including emerging issues
- e. preparing environmental assessments for biodiversity themes and arrange for their publication
- f. ensuring assessments are based on results of monitoring, on research related to monitoring and assessment, and on data and information from other sources
- g. providing advice to the Commission on, and contributing and responding to, assessments undertaken by other Committees or by fora outside OSPAR;
- h. developing analytical tools and criteria for biodiversity assessment procedures, and develop assessment tools for the purposes coherent conduct of assessments

Information exchange and consultation with other OSPAR Committees

7. BDC shall ensure exchange of information as required but specifically:

- a. with EIHA in respect of pressures of human activities on species, habitats and ecosystem functioning;

⁴ Addition proposed by FOEI

⁵ Addition proposed by UK, as this is a core element of BDCs work (through ICG-COBAM)

⁶ Addition proposed by UK

b. with HASEC, OIC and RSC in respect of the pressures of man-made substances including greenhouse gases

8. BDC shall also provide an annual progress report on the ecosystem approach, MSFD and other key cross-cutting issues to the OSPAR Coordination Group

9. BDC shall report on its work non-CoG issues to the OSPAR Commission and advise the Commission on specific questions related to its work remitted to it by the Commission.

Working Groups and Intersessional Correspondence Groups (ICGs)

10. BDC shall not have any dedicated Working Groups but will establish ICGs as required to progress individual products set out in its annual Programme of Work and to facilitate consideration of impact of pressures against ecosystem state.

Terms of Reference for the Environmental Impact of Human Activities Committee (EIHA)

1. The function of the Environmental Impact of Human Activities Committee (EIHA) is to facilitate the implementation of the OSPAR Strategy and in particular the thematic Biodiversity Strategy.

Strategy implementation

2. In accordance with the Biodiversity Strategy, EIHA shall:
- promote integrated management of human activities in the marine environment
 - ensure the effects of human activities, both individually and cumulatively, do not adversely affect ecosystem services or species and habitats; and
 - take specific actions on litter and noise.
3. In doing so EIHA shall pay particular attention to the conclusions and recommendations of the QSR 2010 on physical hydrological and biological pressures and assess compliance of Contracting Parties with agreed programmes and measures.
4. EIHA shall also maintain appropriate interaction with other international organisations and industry. This is particularly relevant to fisheries, international shipping and pollution preparedness and response (Bonn Agreement).

MSFD GES descriptors

5. EIHA shall in particular take into account Descriptors 2, 7, 10 and 11, preparing draft measures as necessary to control adverse impacts of non-indigenous species, impacts of anthropogenic activities on marine substrates and the water column, marine litter and underwater noise levels.^{7,8}

Monitoring and assessment

6. EIHA shall maintain appropriate monitoring and assessment in line with the JAMP 2010-2014, paying particular attention to:
- levels of activity of established activities e.g. dredging and dumping of dredged material, munitions, windfarms, artificial reefs
 - technical issues associated with the control of where human activities take place (i.e. MSP, socio-economics)
 - preparing environmental assessments for human activity themes and arrange for their publication
 - ensuring assessments are based on results of monitoring, on research related to monitoring and assessment, and on data and information from other sources
 - providing advice to the Commission on, and contributing and responding to, assessments undertaken by other Committees or by fora outside OSPAR;
 - developing analytical tools and criteria for human impact assessment procedures, and develop assessment tools for the purposes coherent conduct of assessments
 - [assessing the impact of the extraction of marine-sourced cooling water]⁹.

Information exchange and consultation with other OSPAR Committees

7. EIHA shall ensure exchange of information as required but specifically:

⁷ Alternative proposal by UK: EIHA shall in particular take account of the need to develop indicators, targets and monitoring programmes associated with descriptors 2, 7, 10 and 11 and the need to assess progress towards the achievement of good environmental status, preparing any draft measures agreed to be necessary resulting from coordination by Member States /Contracting Parties, or supporting

⁸ Alternative proposed by EC: EIHA shall in particular take account of the need by Parties to develop indicators, targets and monitoring programmes, and draft measures associated with Descriptors 2,7,10 and 11, ... Namely to control adverse impacts of non-indigenous species, impacts of anthropogenic activities on marine substrates and the water column, marine litter and underwater noise levels.

⁹ Addition proposed by FOEI

- a. with BDC in respect of pressures of human activities on species, habitats and ecosystem functioning. For example, the good environmental status of sea floor integrity must relate the impacts of human activities to the condition of benthic communities;
 - b. with OIC in respect of exploration activities and siting of structures in marine waters
8. EIHA shall also provide an annual progress report on the ecosystem approach, MSFD and other key cross-cutting issues to the OSPAR Coordination Group.
 9. EIHA shall report on its non-CoG related work to the OSPAR Commission and advise the Commission on specific questions related to its work remitted to it by the Commission.

Working Groups and Intersessional Correspondence Groups (ICGs)

10. EIHA shall retain oversight of the North Sea Network Working Group (NSN) given that group's interest in shipping.
11. ICGs shall be established as required to progress individual products set out in the Committee's annual Programme of Work.

Terms of Reference for the Hazardous Substances and Eutrophication Committee (HASEC)

1. The function of the Hazardous Substances and Eutrophication Committee (HASEC) is to facilitate the implementation of the OSPAR Strategy and in particular both the Hazardous Substances and Eutrophication Thematic Strategies. In addition, HASEC will be responsible for inputs, trends, effects and concentrations of hazardous substances and nutrients¹⁰.

Strategy implementation

2. In accordance with the Hazardous Substances Strategy, HASEC shall:

- a. take forward OSPAR's work to continuously reduce discharges, emissions and losses of hazardous substances, with the ultimate aim of achieving concentrations in the marine environment near background values for naturally occurring substances and close to zero for man-made synthetic substances.
- b. make every endeavour, through appropriate actions and measures, to move towards the targets of:
 - i. the cessation of discharges, emissions and losses of hazardous substances by the year 2020;
 - ii. achieving concentrations of contaminants at levels not giving rise to pollution effects;
 - iii. ensuring contaminants in fish and other seafood for human consumption do not exceed levels established by Community legislation or other relevant standards.

3. In accordance with the Eutrophication Strategy, HASEC shall:

- a. evaluate the extent of eutrophication problems in the OSPAR maritime area, taking into account any additional impacts linked to climate change
- b. identify actions needed to achieve non-problem area status recognising that approaches may differ according to the size and nature of catchments

4. In doing so HASEC shall pay particular attention to the conclusions and recommendations of the QSR 2010 and assess compliance of Contracting Parties with agreed programmes and measures. In particular for eutrophication this includes PARCOM Recommendations 88/2, 89/4 and 92/7.

5. HASEC shall also maintain appropriate interaction with other international organisations and industry.

MSFD GES descriptors

6. HASEC shall in particular take into account Descriptors 5, 8 and 9, preparing draft measures, or supporting the development of measures in other fora, as necessary to control use and reduction of discharges of chemicals (most specifically those identified by OSPAR as being Chemicals for Priority Action) and nutrients. In addition HASEC shall consider relevant links to 'good ecological status' under the Water Framework Directive.^{11, 12, 13}

Monitoring and assessment

7. HASEC shall maintain appropriate monitoring and assessment in line with the JAMP 2010-2014, paying particular attention to:

- a. For hazardous substances:

¹⁰ France suggest to delete sentence or insert 'the monitoring of' inputs, trends... on the basis that HASEC can only be responsible for the relevant OSPAR thematic strategies

¹¹ Alt suggested by UK: HASEC shall in particular take account of the need by Parties to develop indicators, targets and monitoring programmes associated with descriptors 5 and 8 and the need to assess progress towards the achievement of good environmental status, preparing any draft measures agreed to be necessary resulting from coordination by Member States / Contracting Parties or supporting

¹² Alt suggested by EC: HASEC shall in particular take into account the need by Parties to develop indicators, targets and monitoring programmes, and draft measures associated with Descriptors 5, 8 and 9or supporting the development of measures in other fora.

¹³ Denmark would prefer 'In addition HASEC shall consider relevant links to 'good environmental status' under the Water Framework Directive and MSFD'

- i. maintaining the List of Chemicals for Priority Action, and associated Background Documents, and the List of Substances of Possible Concern (including deselection where appropriate)
- ii. quantification of regional sources, releases and pathways of hazardous substances on the List of Chemicals for Priority Action
- iii. effective regional coordinated monitoring and assessment
- b. For eutrophication:
 - i. ensuring the Common Procedure for the identification of the Eutrophication status of the maritime area is revised as necessary to fulfil the requirements of the MSFD
 - ii. evaluating and reporting on the effectiveness of measures addressing eutrophication problems, including modelling of reduction scenarios
 - iii. coordinating the development of measures to reduce or eliminate anthropogenic eutrophication in marine waters in problem areas
- c. For both hazardous substances and eutrophication:
 - i. preparing appropriate environmental assessments and arranging for their publication
 - ii. ensuring assessments are based on results of monitoring, on research related to monitoring and assessment, and on data and information from other sources
 - iii. providing advice to the Commission on, and contributing and responding to, assessments undertaken by other Committees or by fora outside OSPAR;
 - iv. developing analytical tools and criteria for assessment procedures linked to hazardous substances and eutrophication, and developing assessment tools for the purposes of coherent conduct of assessments.

Information exchange and consultation with other OSPAR Committees

7. HASEC shall ensure exchange of information as required but specifically:
 - a. with OIC in respect of the phase out of hazardous substances; and
 - b. with BDC in respect of pressures and impacts on ecosystems and biodiversity of the maritime area
8. HASEC shall also provide an annual progress report on the ecosystem approach, MSFD and other key cross-cutting issues to the OSPAR Coordination Group
9. HASEC shall report on its non-CoG related work to the OSPAR Commission and advise the Commission on specific questions related to its work remitted to it by the Commission.

Working Groups and Intersessional Correspondence Groups (ICGs)

10. HASEC shall retain oversight of/establish dedicated Working Groups for:
 - a. Eutrophication (E)
 - b. Monitoring and trends and Effects of Substances in the Marine Environment (MIME)
 - c. Inputs to the Marine Environment (INPUT)
11. ICGs shall be established as required to progress individual products set out in the Committee's annual Programme of Work.

Terms of Reference for the Offshore Industry Committee (OIC)

1. The function of the Offshore Industry Committee (OIC) is to facilitate the implementation of the OSPAR Strategy and in particular the Offshore Oil and Gas Thematic Strategy.

Strategy implementation

2. In accordance with the Offshore Oil and Gas Strategy, OIC shall:
- a. develop and apply a risk-based approach for offshore activities¹⁴
 - b. keep under review the need for actions to prevent other potential adverse effects from offshore activities; and
 - c. consider implications of decommissioning of redundant oil and gas installations.
3. In doing so OIC shall pay particular attention to the conclusions and recommendations of the QSR 2010 and assess compliance of Contracting Parties with agreed programmes and measures.
4. OIC shall also maintain appropriate interaction with other international organisations and industry.

MSFD GES descriptors

5. OIC shall in particular take into account Descriptors 8, 9 and 11, preparing draft measures as necessary to control use and reduction of discharges of offshore chemicals (including those identified by OSPAR as being Chemicals for Priority Action), reducing discharges of oil and radioactive substances, and underwater noise levels.

Monitoring and assessment

6. OIC shall maintain appropriate monitoring and assessment in line with the JAMP 2010-2014, paying particular attention to:
- a. annual data collection and periodic evaluation of the impact of discharges, emissions and losses of substances from offshore sources, which cause or are likely to cause pollution
 - b. improvement of tools to collect, process and interpret such data, together with appropriate initiation and review of technical studies including BAT and BEP
 - c. assessing reports from Contracting Parties on the effectiveness of programmes and measures implemented by them and assessing the need for any further programmes and measures
 - d. identification of specific issues such as cuttings piles
 - e. preparing appropriate assessments and arranging for their publication
 - f. ensuring assessments are based on results of monitoring, on research related to monitoring and assessment, and on data and information from other sources
 - g. providing advice to the Commission on, and contributing and responding to, assessments undertaken by other Committees or by fora outside OSPAR;
 - h. developing analytical tools and criteria for assessment procedures linked to the impact of offshore activities, and developing assessment tools for the purposes of coherent conduct of assessments.
 - i. [developing standards for acceptable underwater noise levels in terms of impact on marine fauna]^{15, 16}.
 - j. [following CCS activities to assess if the carbon dioxide retained permanently in geological formations will not lead to significant adverse consequences for the marine environment, human health and other legitimate uses of the maritime area.]¹⁷
 - k. [progressing research into potential impact of regular platform lighting on fauna]¹⁸

¹⁴ France consider this to be too vague and would like specific activities specified (e.g. produced water)

¹⁵ Addition proposed by FOEI

¹⁶ UK suggest developing targets and indicators for underwater noise levels in line with the requirements and associated activities for the MSFD

¹⁷ Addition proposed by France

¹⁸ Addition proposed by France

Information exchange and consultation with other OSPAR Committees

7. OIC shall ensure exchange of information as required but specifically:
- a. with RSC in respect of discharges of radionuclides by the oil and gas industry;
 - b. with HASEC in respect of the phase out of hazardous substances; and
 - c. with BDC in respect of pressures and impacts on ecosystems and biodiversity of the maritime area,[and the development of the marine protected area network (e.g. MPAs in conjunction with offshore sites)].¹⁹
8. OIC shall also provide an annual progress report on the ecosystem approach, MSFD and other key cross-cutting issues to the OSPAR Coordination Group
9. OIC shall report on its non-CoG related work to the OSPAR Commission and advise the Commission on specific questions related to its work remitted to it by the Commission.

Working Groups and Intersessional Correspondence Groups (ICGs)

10. OIC shall not have any dedicated Working Groups but will establish ICGs as required to progress individual products set out in its annual Programme of Work.

¹⁹ Addition proposed by FOEI

Terms of Reference for the Radioactive Substances Committee (RSC)

1. The function of the Radioactive Substances Committee (RSC) is to facilitate the implementation of the OSPAR Strategy and in particular the Radioactive Substances Thematic Strategy.

Strategy implementation

2. In accordance with the Radioactive Substances Strategy, RSC shall:

- a. prevent pollution of the maritime area from ionising radiation through progressive and substantive reductions of discharges, emissions and losses of radioactive substances; and
- b. ensure that by 2020 additional concentrations in the marine environment above historic levels resulting from such discharges, emissions and losses are close to zero.
- c. taking into account legitimate uses of the sea, technical feasibility, and radiological impacts on man and biota].²⁰

3. In doing so RSC shall pay particular attention to the conclusions and recommendations of the QSR 2010 and assess compliance of Contracting Parties with agreed programmes and measures.

4. RSC shall also maintain appropriate interaction with other international organisations and industry, taking into account all recommendations and methodologies, as well as legally binding documents, that have been developed in other international forums which are relevant to the OSPAR Strategy.

MSFD GES descriptors

5. RSC does not have a specific locus within the MSFD, however it is incumbent on RSC to develop and periodically review environmental quality criteria to evaluate the impacts of discharges on the marine environment. In this context RSC shall continue to work to resolve the 'Bremen' issues (applying the baseline for tritium, dealing with exceptional discharges and a method to take account of variability in the level of operation of nuclear installations).

Monitoring and assessment

6. RSC shall maintain appropriate monitoring and assessment in line with the JAMP 2010-2014, paying particular attention to:

- a. annual data collection and periodic evaluation of the impact of anthropogenic discharges, emissions and losses of radioactive substances, and of environmental concentrations of such substances from both nuclear and non-nuclear sectors
- b. improvement of tools to collect, process and interpret such data, together with appropriate initiation and review of technical studies including BAT and BEP
- c. assessing reports from Contracting Parties on the effectiveness of programmes and measures implemented by them and assessing the need for any further programmes and measures
- d. identification of specific issues such as [\[review\]](#) of national plans and [\[\]](#) historic dump sites²¹
- e. preparing appropriate assessments and arranging for their publication
- f. ensuring assessments are based on results of monitoring, on research related to monitoring and assessment, and on data and information from other sources
- g. providing advice to the Commission on, and contributing and responding to, assessments undertaken by other Committees or by fora outside OSPAR;²²
- h. developing analytical tools and criteria for assessment procedures linked to the impact of radioactive substances, and developing assessment tools for the purposes of coherent conduct of assessments.

Eliminado: adequacy

Eliminado: monitoring of

Information exchange and consultation with other OSPAR Committees

²⁰ [Addition proposed by France based on the Strategy](#)

²¹ [Changes proposed by France](#)

²² [France place a reservation on \(g\) subject to clarification](#)

7. RSC shall ensure exchange of information as required but specifically:
 - a. with OIC in respect of discharges of radionuclides by the oil and gas industry; and
 - b. with BDC in respect of pressures and impacts on ecosystems and biodiversity of the maritime area
8. RSC shall also provide an annual progress report on the ecosystem approach, MSFD and other key cross-cutting issues to the OSPAR Coordination Group
9. RSC shall report on its non-CoG related work to the OSPAR Commission and advise the Commission on specific questions related to its work remitted to it by the Commission.

Working Groups and Intersessional Correspondence Groups (ICGs)

10. RSC shall not have any dedicated Working Groups but will establish ICGs as required to progress individual products set out in its annual Programme of Work.